

This drawing is the property of MELTRIC Corporation, Franklin (Milwaukee), Wisconsin, USA. Any unauthorized copying of this drawing by any means, or disclosure of its contents to any person not authorized by MELTRIC Corporation or its agents to receive it, is strictly prohibited.

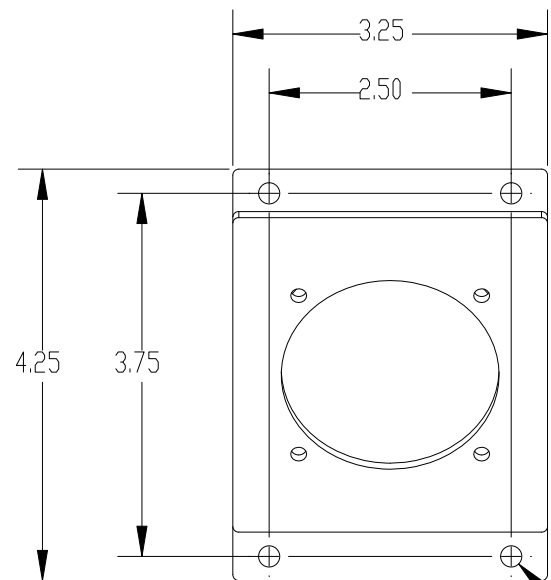

4X  $\phi$  .22

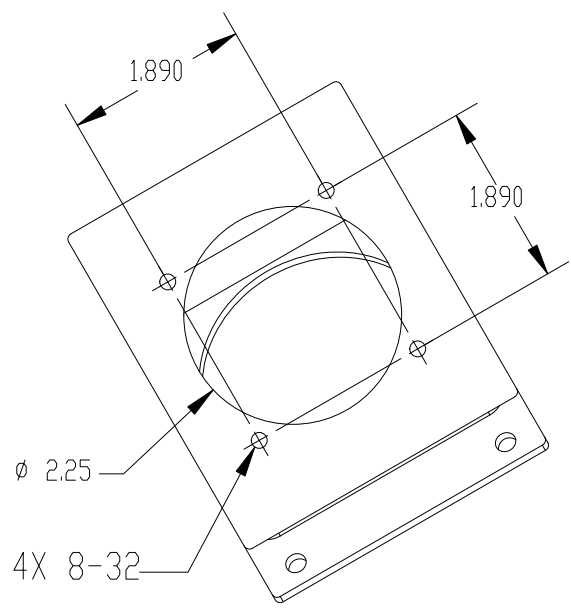

VIEW A-A

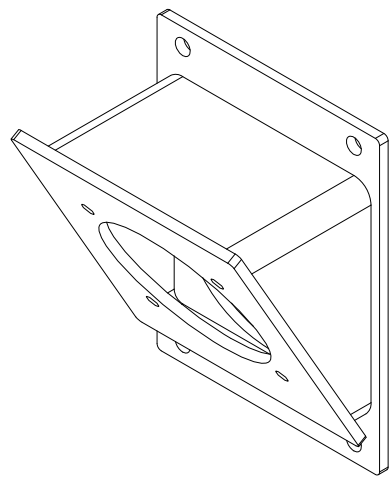
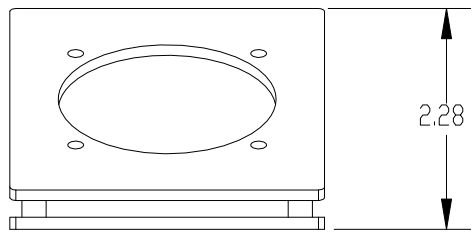
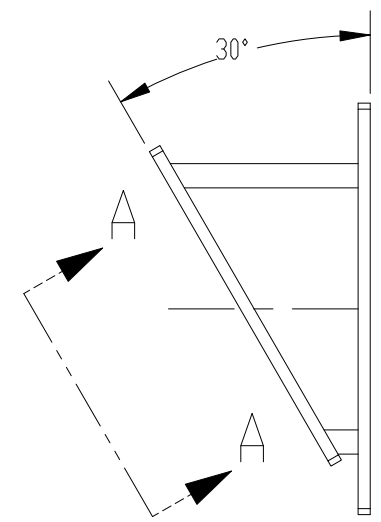

TOLERANCES UNLESS OTHERWISE SPECIFIED		 A COMPANY OF MATERIAL ELECTRIC				
MACHINED SURFACES	125 $\sqrt{\text{MAX}}$			ENGLISH		
GROUND SURFACES	32 $\sqrt{\text{MAX}}$	0.X $\pm 0.05$	DRAWN	APPROVED	DRAWING TITLE:	
ANGLE TOLERANCE	$\pm 1^\circ$	0.XX $\pm 0.01$	DATE:	SCALE	PN STAINLESS STEEL ANGLE	
REMOVE BURRS & SHARP EDGES TO .015 MAX.		0.XXX $\pm 0.005$	SHEET:	NTS	MATERIAL:	
DIMENSIONS SHOWN IN OVALS ARE INSPECTION DIMENSIONS.			1 OF 1	7X1M3	STAINLESS STEEL	
					PART NUMBER	REVISION